

MULTIDOT

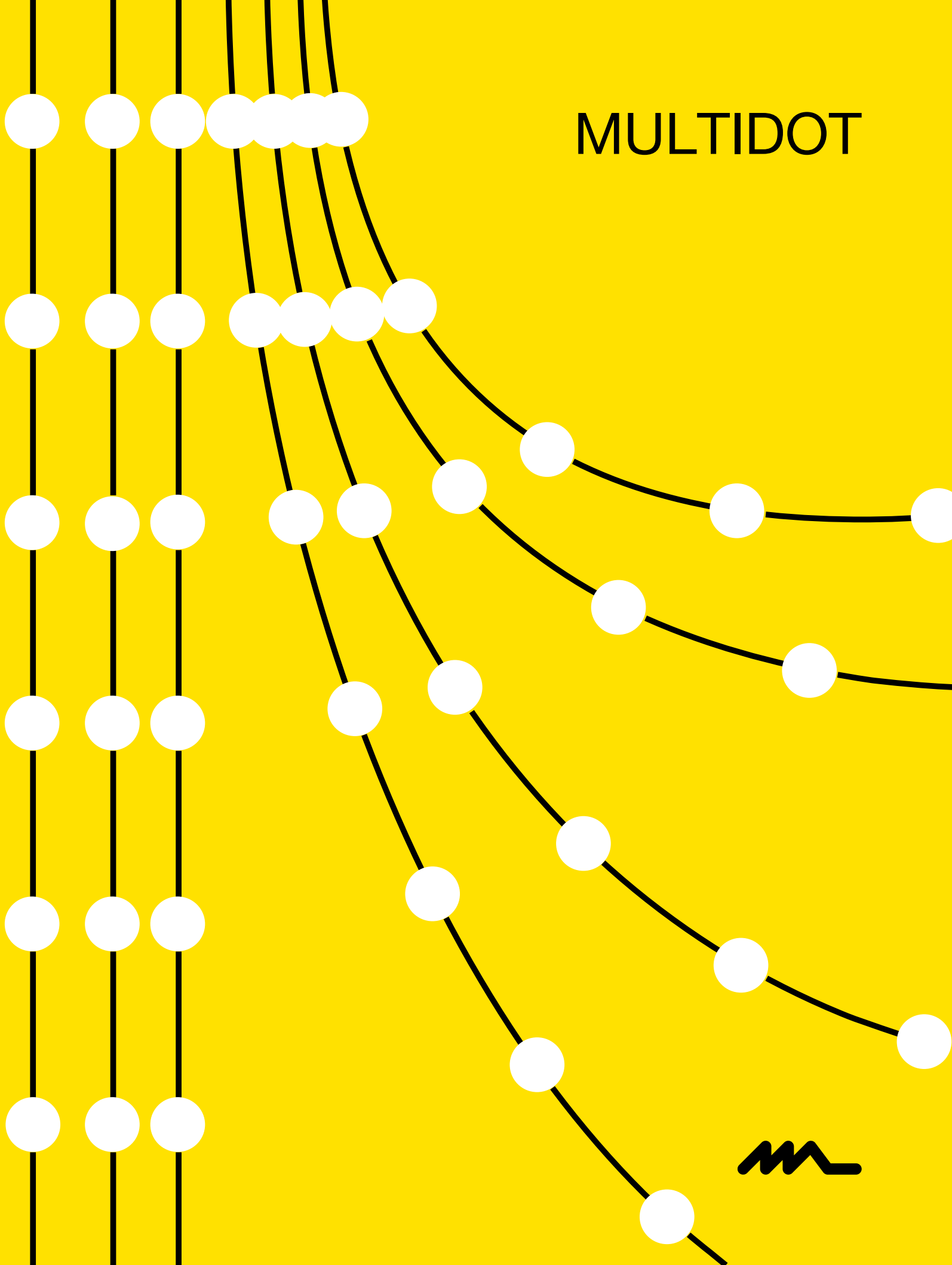

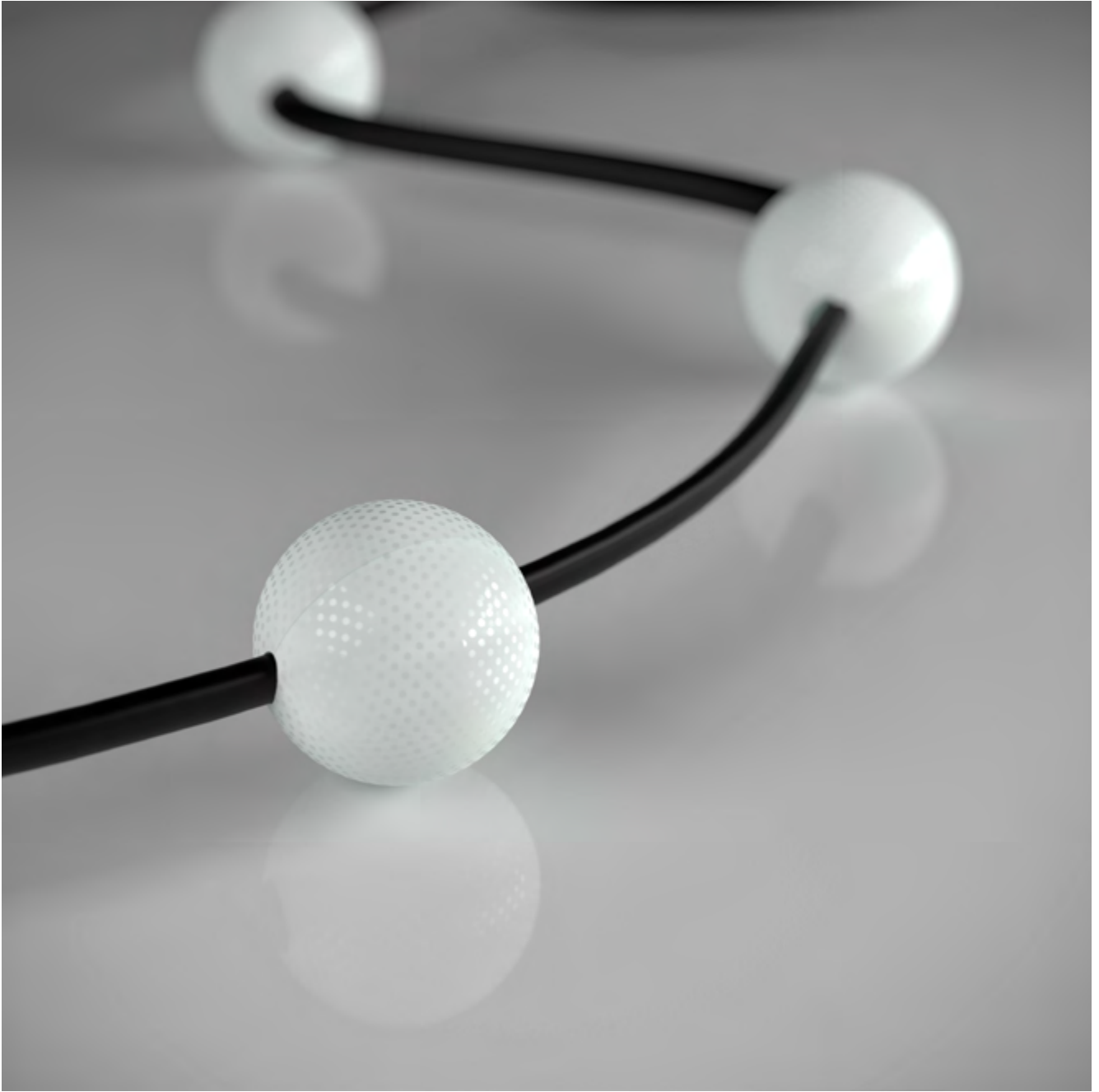

MULTIDOT

BRIAN SIRONI









MULTIDOT

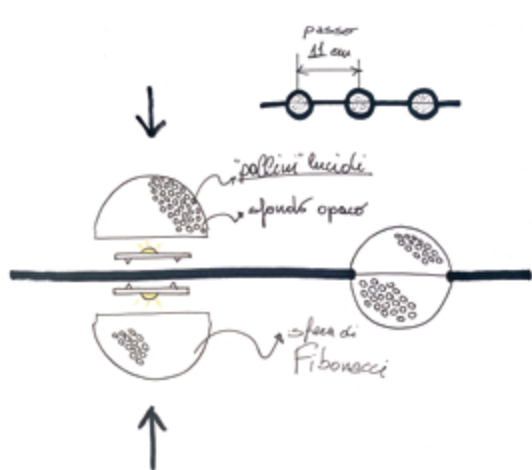
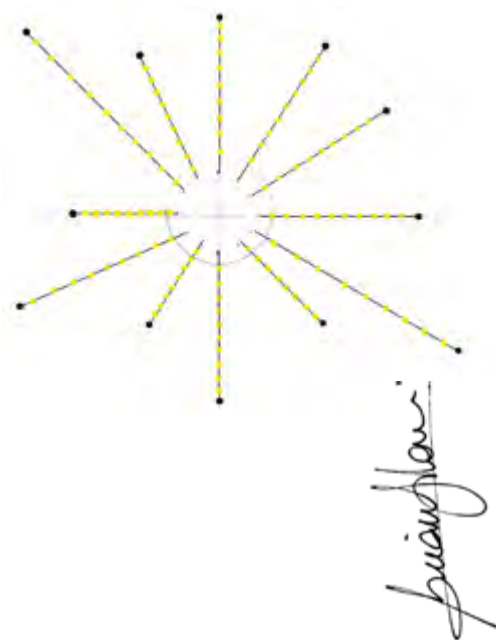
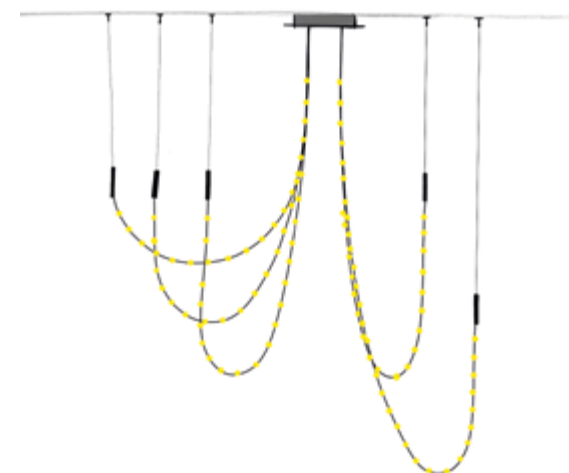

Ispirandosi ai chandelier del passato, Multidot propone una interpretazione moderna del candelabro, sia da un punto di vista compositivo/espressivo che tecnologico, consentendo al progettista la massima personalizzazione e libertà creativa. I cavi elettrici a basso voltaggio 24V a cui vengono agganciate le sfere luminose a LED, sono stati specificatamente progettati per diventare l'elemento strutturale e decorativo della lampada. Multidot è componibile, estremamente flessibile e configurabile: in ogni composizione può variare la lunghezza, il numero e il posizionamento dei cavi elettrici, oltre che il numero delle sfere luminose. In aggiunta alla cura per l'aspetto scenico c'è stata un'attenta progettazione del dettaglio passando dal macro al micro, ogni sfera luminosa LED è stata impreziosita da una finitura superficiale: una serie di micro pallini lucidi è stata distribuita su un fondo opaco attraverso la successione di Fibonacci, generando un piacevole effetto di pieni e vuoti.

Inspired by the chandeliers of the past, Multidot offers a modern interpretation of the candelabra, both from a compositional/expressive and technological point of view, allowing the designer maximum customisation and creative freedom. The LED light spheres are attached to the low-voltage 24V electric cables which are specifically designed to become the structural and decorative element of the lamp. Multidot is modular, extremely flexible and configurable: the length, number and positioning of the electrical cables, as well as the number of light spheres, can vary in each composition. In addition to the attention for the scenic and aesthetic aspect, there has been a careful design of the detail, going from the macro to the micro. Each LED light sphere has been enriched with a surface finish: a series of shiny micro dots has been distributed on the matte background through the Fibonacci succession, generating a pleasant effect of solids and voids.

BRIAN SIRONI







EXAMPLES | SERIE XS | cable 2,1m | 8 spheres each cable

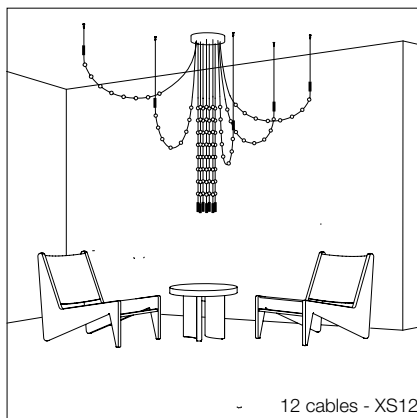
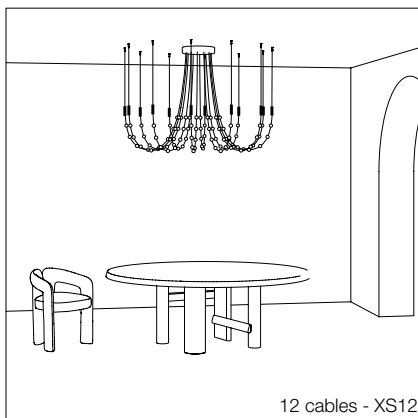
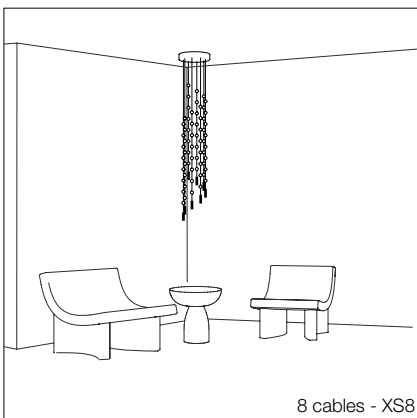
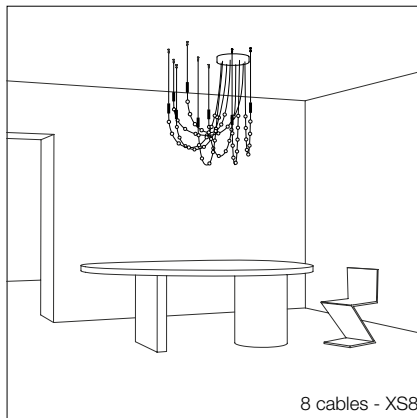
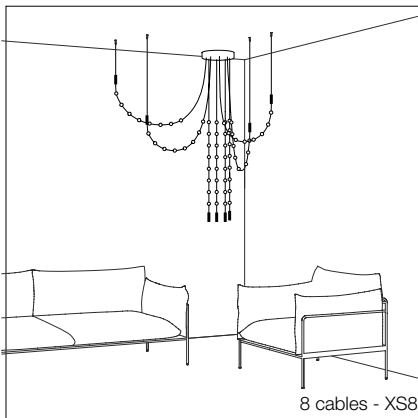
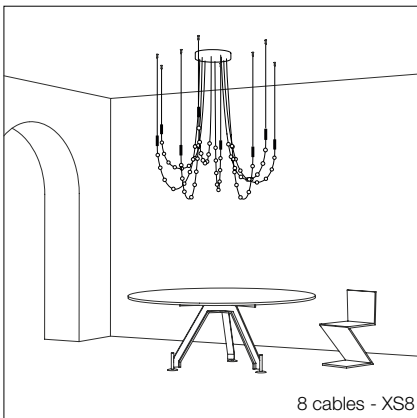
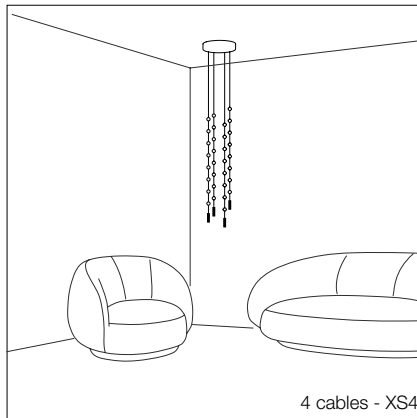
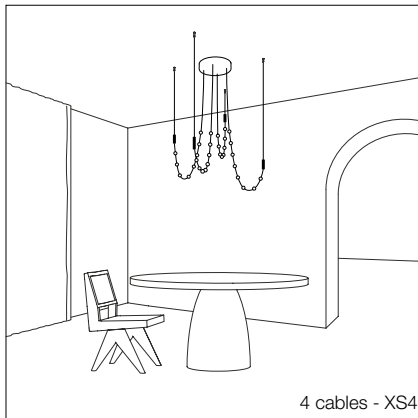
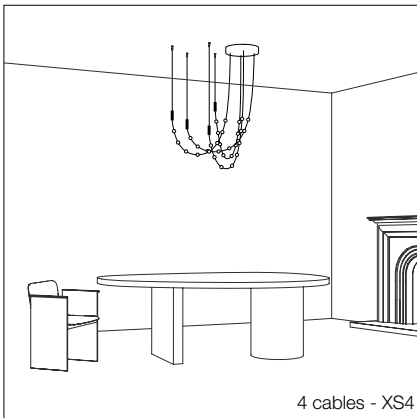
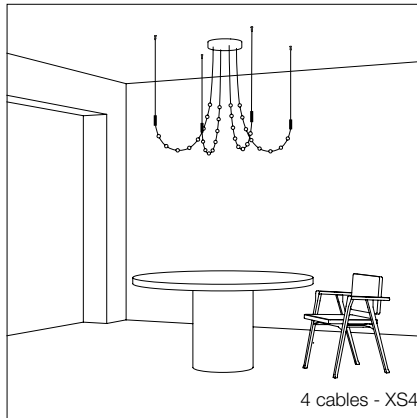
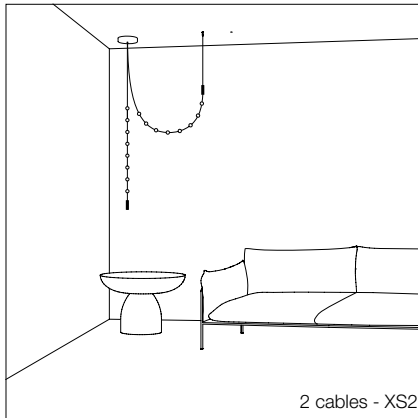
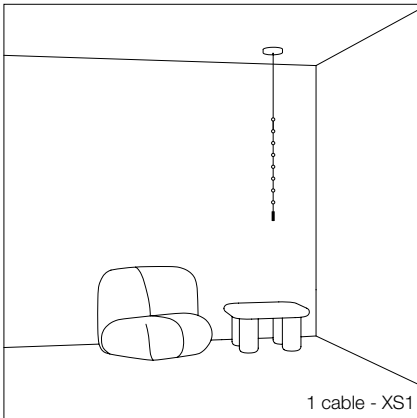



EXAMPLES | SERIE S | cable 2,8m | 12 spheres each cable

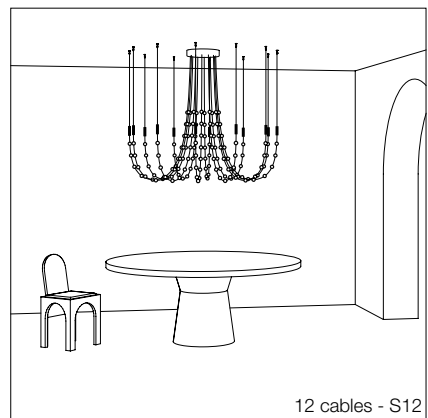
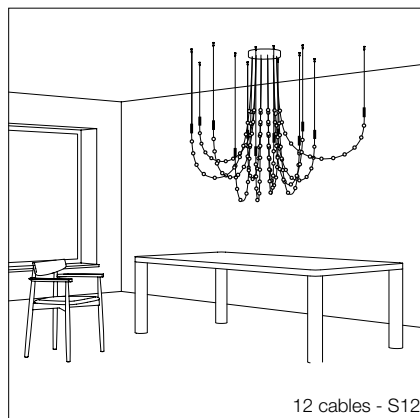
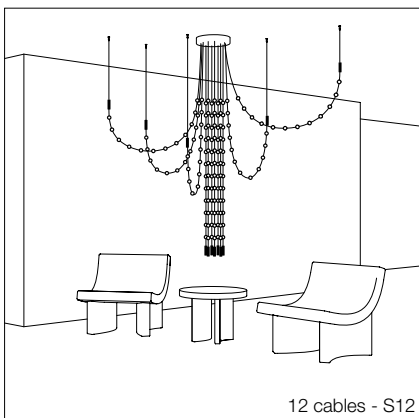
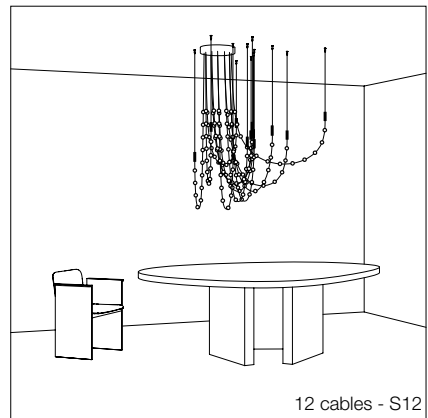
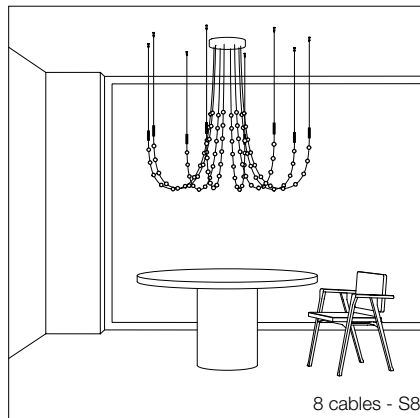
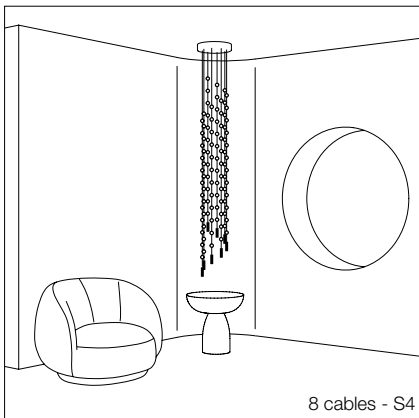
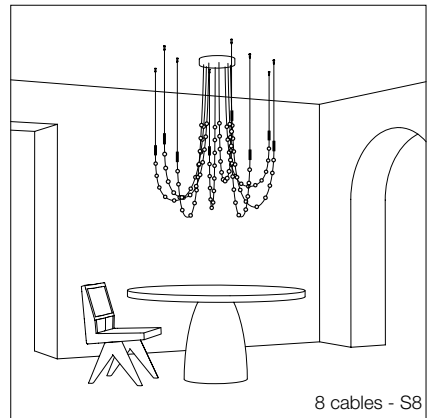
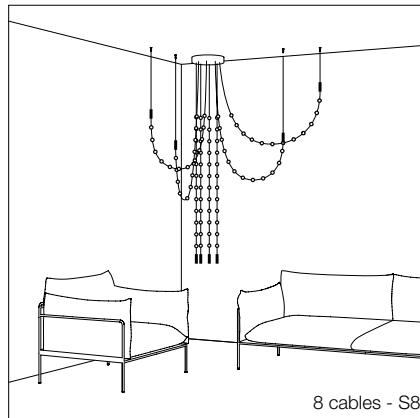
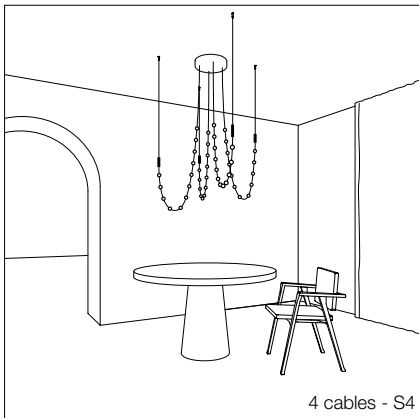
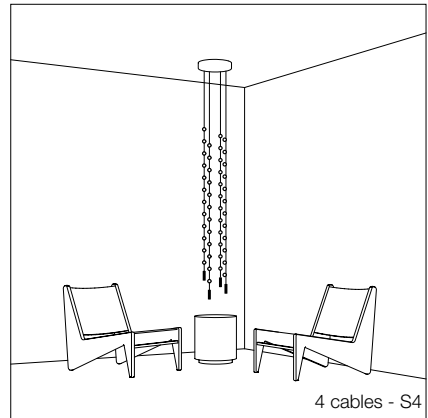
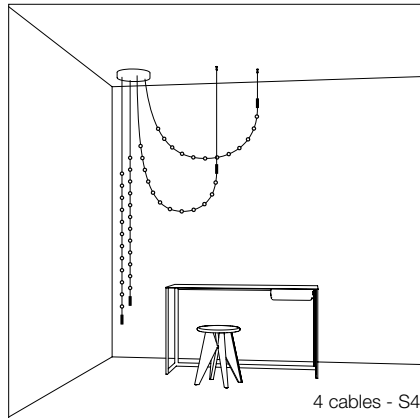
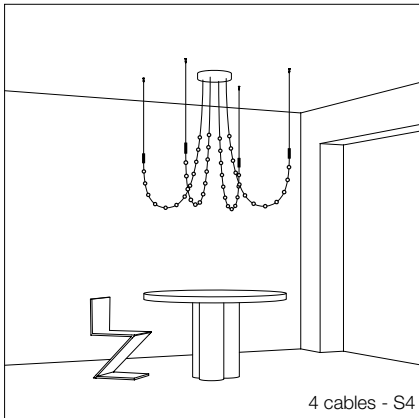



EXAMPLES | SERIE M | cable 3,8m | 16 spheres each cable

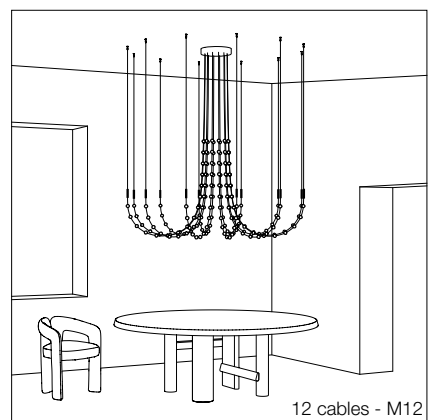
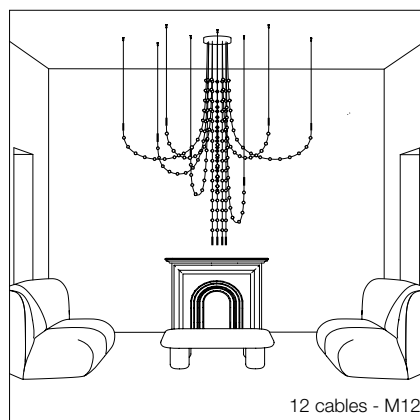
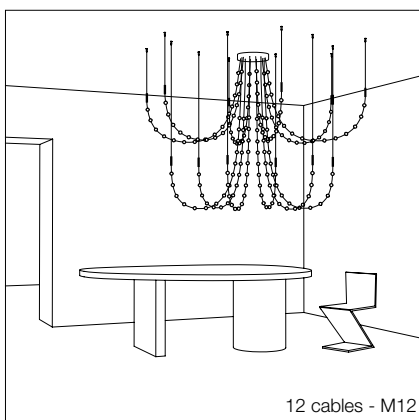
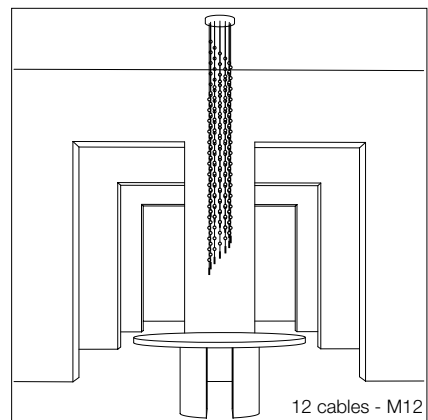
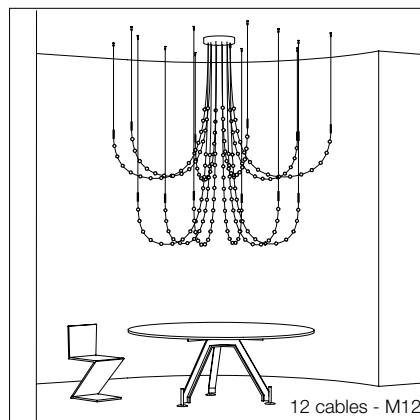
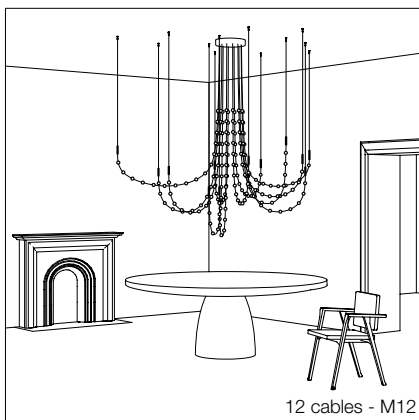
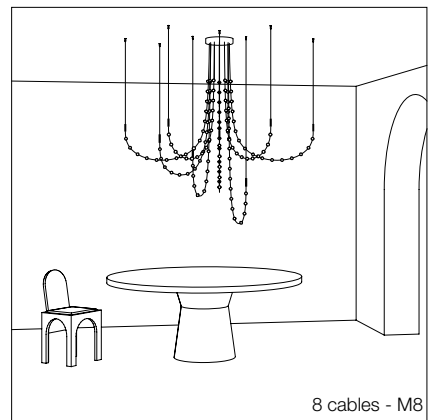
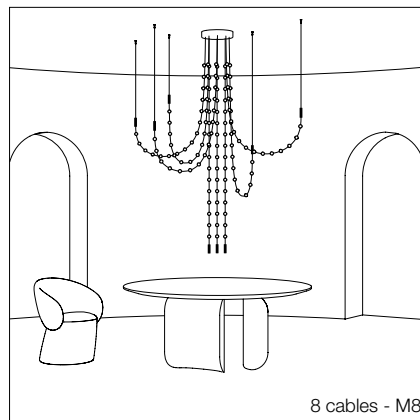
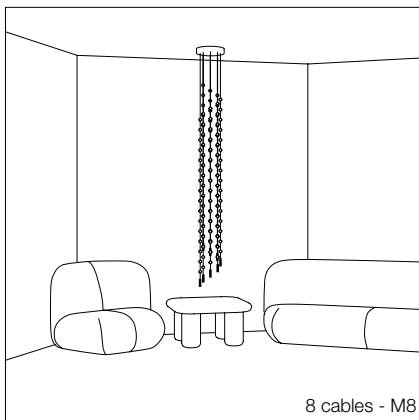
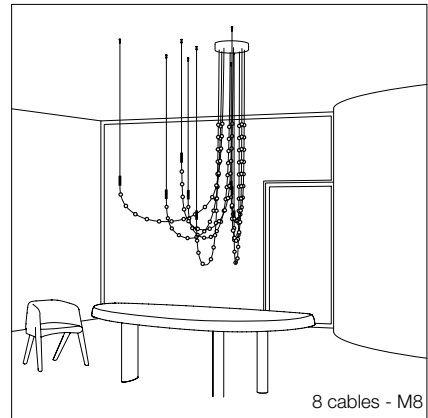
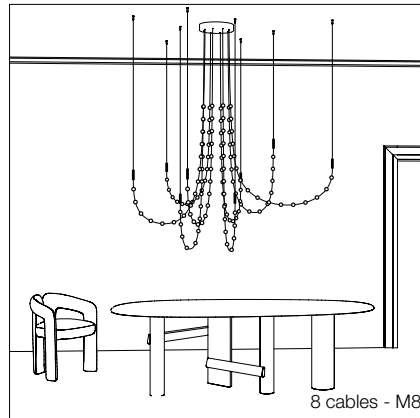
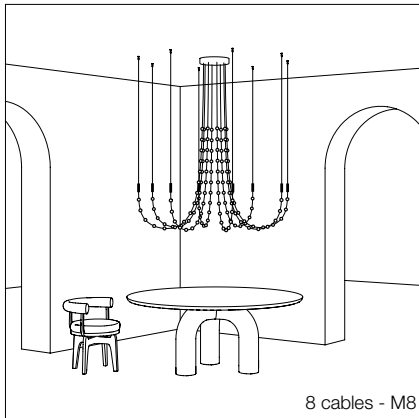



MULTIDOT

BRIAN SIRONI



Lampada a sospensione a luce diffusa componibile in diverse combinazioni. Formata da un numero variabile di cavi elettrici a 24V studiati appositamente, disponibili in 5 lunghezze: serie XS composta da cavi di 2,1 m con 8 sfere a LED, serie S composta da cavi di 2,8 m con 12 sfere a LED, serie M composta da cavi di 3,8 m con 16 sfere a LED, serie L composta da cavi di 4,5 m con 24 sfere a LED, serie XL composta da cavi di 5,5 m con 32 sfere a LED. I cavi sono completi di contrappeso cilindrico di colore nero, di cavo in acciaio e supporto bloccafune per il fissaggio al soffitto secondo la configurazione. Le sfere opaline sono complete di sorgente di luce a LED da 0,8W.

Disponibili 6 rosoni a soffitto cablati con alimentatore elettronico per le composizioni con 1-2, 4, 8, 12, 18 o 24 cavi.

Disponibile anche un rosone per composizioni lineari da 8 catenarie.

Modular pendant lamp with diffused light that can be configured in different combinations. Consisting of a variable number of specially designed 24V electric cables, available in 5 lengths: XS series consisting of 2.1 m cables with 8 LED spheres, S series consisting of 2.8 m cables with 12 LED spheres, M series consisting of 3.8 m cables with 16 LED spheres, L series consisting of 4.5 m cables with 24 LED spheres, XL series consisting of 5.5 m cables with 32 LED spheres. The cables are equipped with a black cylindrical counterweight, a steel cable and a cable clamp bracket for fixing them to the ceiling. The opal spheres with 0.8W LED light source. Available 6 ceiling rosettes wired with electronic ballast for compositions with 1-2, 4, 8, 12, 18 or 24 cables. Also available is a ceiling rose for linear compositions with 8 catenaries.



MULTIDOT

CAVI / CABLES

XS 8 SFERE / 8 SPHERES

6,4W LED 2700K
cod. 40210.2700.8.11.210.118

6,4W LED 3000K
cod. 40210.3000.8.11.210.118

S 12 SFERE / 12 SPHERES

9,6W LED 2700K
cod. 40210.2700.12.11.280.145

9,6W LED 3000K
cod. 40210.3000.12.11.280.145

M 16 SFERE / 16 SPHERES

12,8W LED 2700K
cod. 40210.2700.16.11.380.200

12,8W LED 3000K
cod. 40210.3000.16.11.380.200

L 24 SFERE / 24 SPHERES

19,2W LED 2700K
cod. 40210.2700.24.11.450.180

19,2W LED 3000K
cod. 40210.3000.24.11.450.180

XL 32 SFERE / 32 SPHERES

25,6W LED 2700K
cod. 40210.2700.32.11.550.195

25,6W LED 3000K
cod. 40210.3000.32.11.550.195

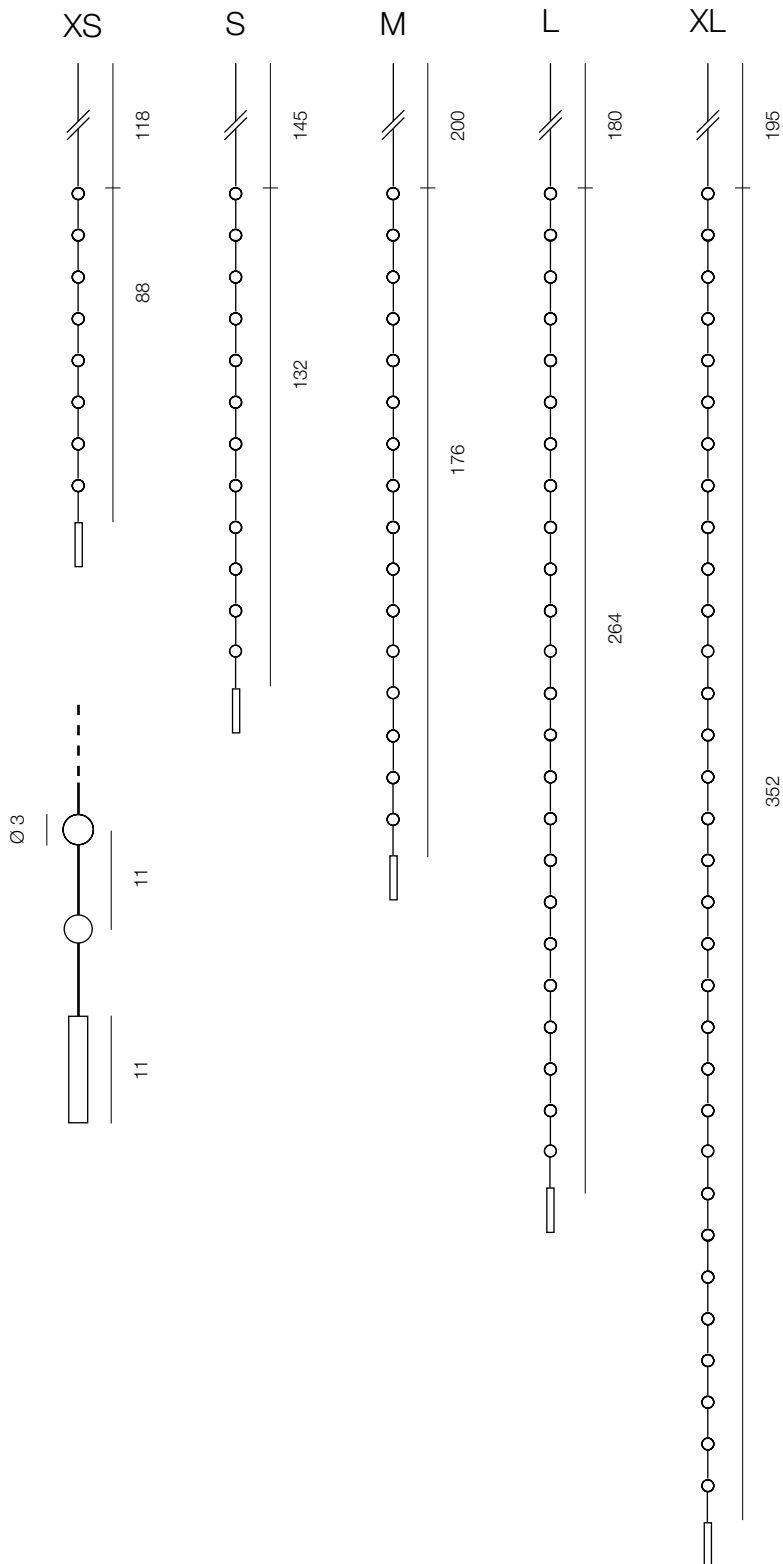

MULTIDOT

ROSONI / CEILING ROSES

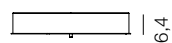

4 CAVI / CABLES

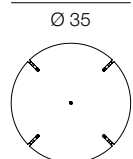

40211.150.4/DIM/NE ● nero / black
 40211.150.4/DIM/BI ○ bianco / white
 150W dimm. Push, Dali2, Pot.10KΩ, 0-10V, 1-10V
 cavi adatti / suitable cables: XS, S, M, L, XL

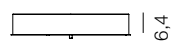

8 CAVI / CABLES

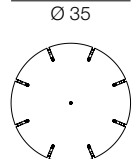

40211.240.8/DIM/NE ● nero / black
 40211.240.8/DIM/BI ○ bianco / white
 240W dimm. Push, Dali2, Pot.10KΩ, 0-10V, 1-10V
 cavi adatti / suitable cables: XS, S, M, L, XL

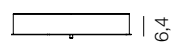

12 CAVI / CABLES

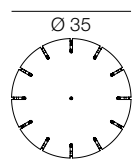

40211.200.12/DIM/NE ● nero / black
 40211.200.12/DIM/BI ○ bianco / white
 200W dimm. Push, Dali2, Pot.10KΩ, 0-10V, 1-10V
 cavi adatti / suitable cables: XS, S, M

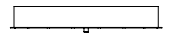

12 CAVI / CABLES

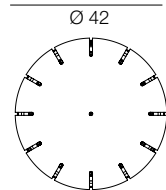

40211.400.12/DIM/NE ● nero / black
 40211.400.12/DIM/BI ○ bianco / white
 400W dimm. Push, Dali2, Pot.10KΩ, 0-10V, 1-10V
 cavi adatti / suitable cables: L, XL

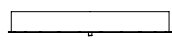

18 CAVI / CABLES

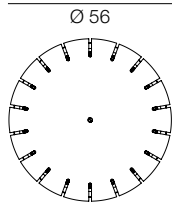

40211.600.18/DIM/NE ● nero / black
 40211.600.18/DIM/BI ○ bianco / white
 600W dimm. Push, Dali2, Pot.10KΩ, 0-10V, 1-10V
 cavi adatti / suitable cables: XS, S, M, L, XL

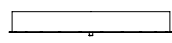

24 CAVI / CABLES

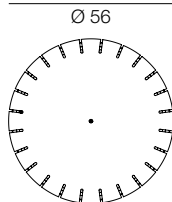

40211.720.24/DIM/NE ● nero / black
 40211.720.24/DIM/BI ○ bianco / white
 720W dimm. Push, Dali2, Pot.10KΩ, 0-10V, 1-10V
 cavi adatti / suitable cables: XS, S, M, L, XL

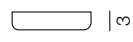

1-2 CAVI / CABLES

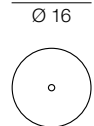

40211.20.1/DIM/NE ● nero / black
 40211.20.1/DIM/BI ○ bianco / white
 20W dimm. Push, Dali2, Pot.10KΩ, 0-10V, 1-10V

1 cavo / cable
 cavi adatti / suitable cables: XS, S, M, L

2 cavi / cables
 cavi adatti / suitable cables: XS, S

La scelta del codice del rosone dipende dalla configurazione scelta ed è vincolato alla somma dei Watt dei singoli cavi.

The choice of ceiling rose code depends on the chosen configuration and is linked to the sum of the watts of the individual cables.

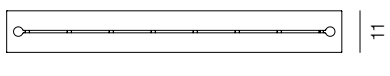
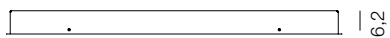

88

LINEARE 8 CAVI / LINEAR 8 CABLES

40220.240.8/DIM/NE ● nero / black

40220.240.8/DIM/BI ○ bianco / white

240W dimm. Push, Dalí2, Pot.10KΩ, 0-10V, 1-10V

cavi adatti / suitable cables: XS, S, M, L, XL







CUSTOM MULTIDOT

Puoi creare un design unico, adattando la disposizione di cavi e numero di sfere in base alle preferenze estetiche e alle esigenze dell'ambiente. Per configurare la tua Multidot:

You can create a unique design, adapting the arrangement of cables and number of spheres to suit your aesthetic preferences and the requirements of your environment. To configure your Multidot:

www.martinelliluce.it

EDITION: 09/2024

Art direction:
Emiliana Martinelli

Layout:
Stefano Citti

3D visualisation:
Studio BF
Brian Sironi
Truetopia

Photo:
Marco Ghilarducci
Emiliana Martinelli

Editing of text:
Emiliana Martinelli
Brian Sironi

Printing in Italy

martinelli luce si riserva il diritto di apportare ai propri modelli in ogni momento senza nessun preavviso, qualsiasi modifica ritenesse opportuna.

martinelli luce reserves the right to introduce any changes to its own models, without prior notice.



martinelli luce spa
via Teresa Bandettini, Lucca
+39 0583 418315 w
www.martinelliluce.it
info@martinelliluce.it

showroom via
santa Lucia 9, Lucca
showroom@martinelliluce.it

martinelli luce

